



Read the following instructions carefully before use.

Special Features

- Can be used on corrugated coated stainless steel tubing (flexible tubes) from DN15 to DN32.
- Special blade prevents damage to the tube.
- Spare blade included.

Using the stripper

1. Loosen the holder knob and, using the scale, adjust the holder to the size of the tube. Then tighten the knob to hold in position on the scale.
2. Pull the spindle lever to hold the tube in place.
3. Remove the plastic coating by turning the stripper in the direction of the cut.

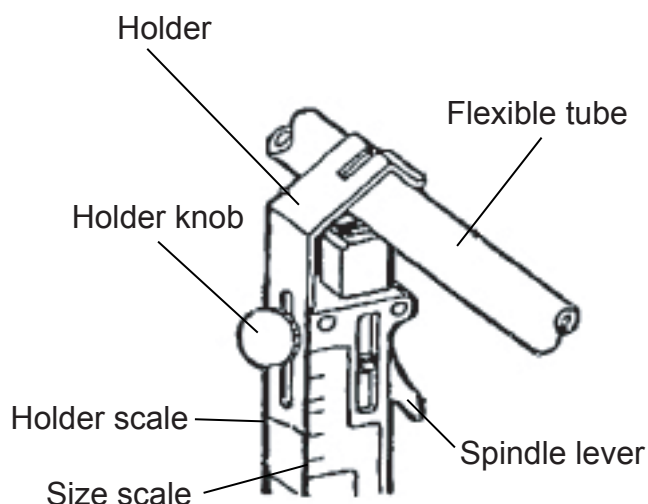

Changing blades

Detaching the blade

- Undo the set screw and remove the spare blade from inside the holder.

Attaching a new blade

1. Place the nut plate in the recess in the spare blade and push the blade as far as it will go into the spindle.
2. Tighten the set screw.

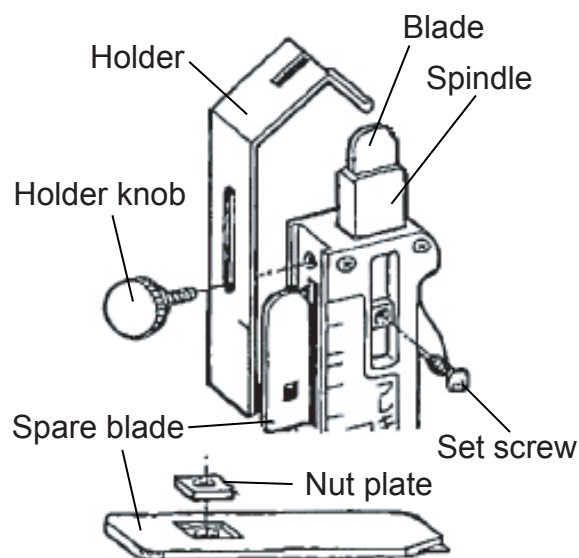

Specifications

Product name	Plastic-coated Flexible Tube Stripper
Applicable Tubing	Corrugated stainless steel tubes (flexible tubes) for gas
Tube sizes	DN15, DN20, DN25, DN32
External dimensions	130mm (l) x 50 mm (w) x 26 mm (h)
Weight	Approx. 80g

REX INDUSTRIES CO., LTD.

Overseas Sales Dept. & Factory :

1-9-3, Hishiyahigashi, Higashi Osaka 578-0948, Japan

Tel.: +81 - (0)72 - 961 - 9820 Fax.: +81 - (0)72 - 961 - 9878

URL <https://www.rexind.co.jp>

FSTP-E1
1305R 0000